

DESCRIPTION

- Metal construction with chrome plated finish
- With the clean and replaceable check valve device

STANDARD

- Comply with GB/T 27710-2011
- Chrome plated finish pass AASS 24H grade 10.
- Flow rate 0.55l/s

WARRANTY

- 5 years limited warranty except artificial damage and chemicals erosion

NOTE: ALL DIMENSIONS ARE IN MM.

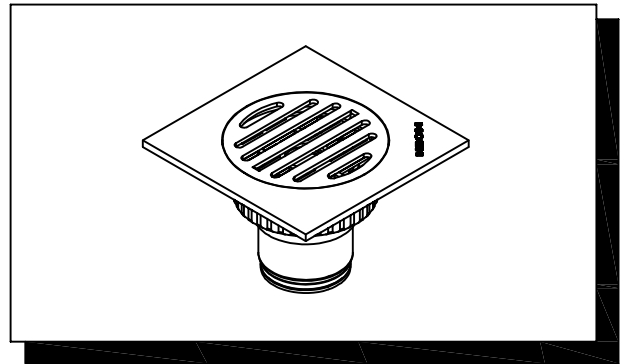

High Flow Floor Drain(BRASS)
Models:3938MCL

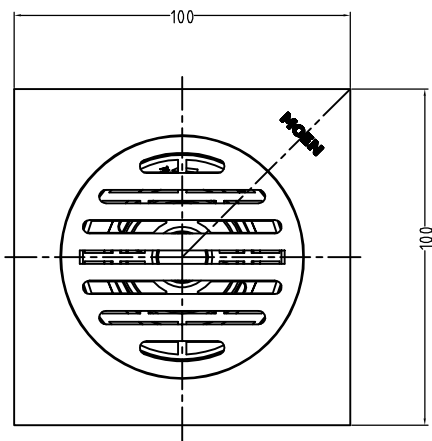
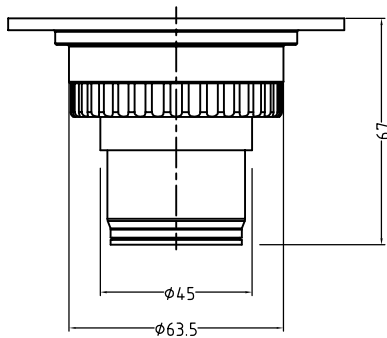

Clean and replace step

